

# Riga Metro technical rider

## Stage scheme

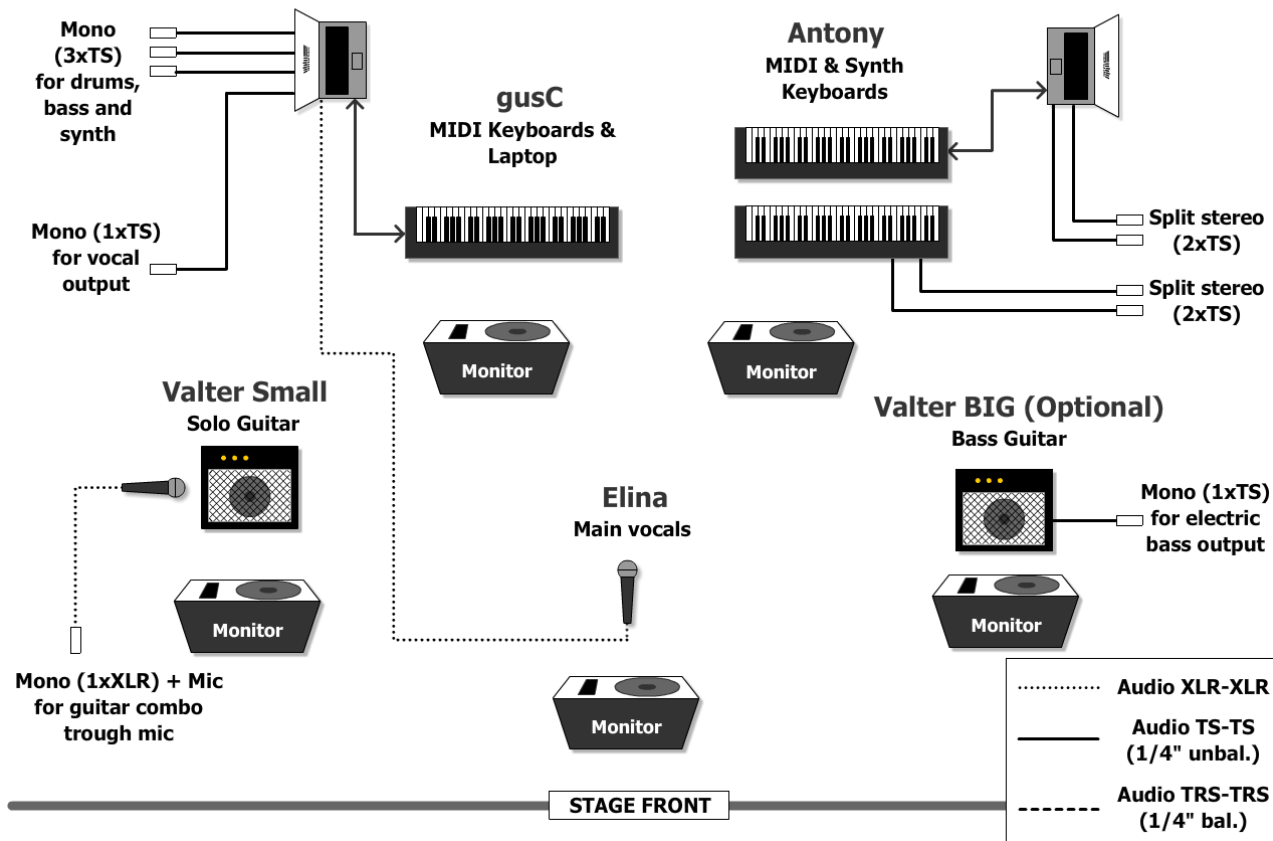

## Stuff provided by organizer

### Elina (main vocal):

- Main: 1x Microphone
- Power supply: -
- Accessories: 1x Microphone stand, 1x XLR<->XLR cable

### Antony (keyboards):

- Main: 4x DI Box
- Power supply: 3x 220V
- Accessories: 4x TS<->TS cable

### gusC (laptop DJ):

- Main: 4x DI Box
- Power supply: 3x 220V (w/o grounding, to cancel out laptop PSU audio interference)
- Accessories: 4x TS<->TS cable

### Valter Small (solo guitar):

- Main: combo (VOX or Orange 50W or similar, **NOT** Marshal, might be provided acc. to special arrangement), 1x Microphone for combo
- Power supply: 3x 220V (2x for FX, 1x for combo)
- Accessories: 1x Microphone stand, 1x XLR<->XLR cable, 1x TS<->TS cable

### Valter BIG (bass guitar):

- Main: combo (AMPEG 100W or similar, might be provided acc. to special arrangement)
- Power supply: 2x 220V (1x for FX, 1x for combo)
- Accessories: 1x TS<->TS cable